

**CALOBRI**<sup>®</sup>



FORGED STEEL

**Ball Valves**

API 6D - BS 5351



■ Introduction	4
■ Over 50 years of Innovation	5
■ Certification	6
■ Qualification	7
■ Trunnion Reduced Bore	8
■ Trunnion Full Bore	9
■ Top Entry Ball Valves	10
■ Full Welded Ball Valves	11
■ Materials	12
■ Transition Pieces	13
■ Extention Detail for Auxiliary Pipes	13
■ Materials	14
■ Note	15

Calobri was founded in 1949 to supply the reconstruction of the petrochemical industry following the war. Soon Calobri specialized in severe application valves in forged steel and gained an excellent reputation in the Italian market. In the late '60s, Calobri began exporting to the nascent North Sea market of Netherlands, Norway and Scotland becoming one of the major suppliers to the off-shore industry. With the expansion of the industry in the '70s, Calobri started to export to the Middle East and Asia while at the same time acquiring approvals from major oil companies.

Today, Calobri is a well known brand on the market with an outstanding record of service and quality. At the 50th anniversary of Calobri, a new, young, dedicated and motivated management team forms the backbone of Calobri at the start of the 21st century.

“

**WE WANT TO  
PROVIDE  
EXCELLENT  
SERVICE AND  
COMPETITIVE  
PRICES  
TO VALVE  
USERS  
WORLDWIDE**

”

Established in 1949, CALOBRI is a privately owned valve manufacturing company.

The new management has extensive experience in the design and manufacture of specialised forged steel valves for all industries.

CALOBRI is based in Settimo Milanese, in the greater Milan area, close to the motorways and within short distance from Linate and Malpensa Airports. The plant is 2 hours away from the major port of Genoa making it easy to quickly dispatch material.

The organization operates within the framework of the ISO9001 certified QA-system.

CALOBRI consists of the following functional departments:

**SALES** keeps contact with the CALOBRI network of agents and distributors, prepares quotations and evaluates the product specifications in order to ensure complete fulfilment of customer orders.

**ENGINEERING** develops and design the products according to the required standards with the aid of the latest CAD-CAM equipment .

**MANUFACTURING** engineers guarantee higher product quality and improved efficiency with the use of the latest CNC equipment and other in-house tools.

**QUALITY CONTROL** a certified system including continuous improvement and monitoring of all internal and subcontracted activities.

**ADMINISTRATION** staff provide the services needed to guarantee prompt service to customers and suppliers. Shipping and invoicing is managed in-house.

## ISO 9001

Calobri operates a fully certified Quality Assurance programme according to ISO9001 which has been recently upgraded. All major suppliers are also fully certified to meet the most stringent international standard of Quality and performance.

## CE Mark - PED

Calobri has been audited and approved by TUV to the new European Community Pressure Equipment Directive which defines a set of design and manufacturing procedures as a minimum standard to ensure that products supplied meet specified safety and performance criteria.



## VALVE ENGINEERING

Calobri has extensive experience in designing valves for severe applications. Calobri developed and patented the monoflange design to meet the requirement for a compact lightweight valve for offshore installation.

## VALVE MANUFACTURING

Calobri has a skilled labour force and a set of high capacity specialized equipment. Calobri uses only forgings from Italy to guarantee the best quality finished products.

## VALVE ASSEMBLY AND TEST

All valves are tested 100% fully to API598 at assembly stage and retested by Final QC Inspectors.

All valves are then supplied with 3.1B certs inclusive of Mill Test reports. Calobri is ISO 9001 approved and since 2002 has PED approval (CE Marking)

## PRODUCT LINE

CALOBRI	Floating						Trunnion Side Entry						Trunnion Top Entry					Trunnion Fully Welded							
	SW - NPT			Flanged - BW			Flanged - BW						Flanged - BW					Flanged - BW							
	#800	#1500	#2500	#150	#300	#600	#900	#1500	#2500	#150	#300	#600	#900	#1500	#2500	#150	#300	#600	#900	#1500	#150	#300	#600	#900	#1500
1/2	✓	✓	✓	✓	✓	✓	✓	✓	✓	✓	✓	✓	✓	✓	✓	✓	✓	✓	✓	✓	✓	✓	✓	✓	✓
3/4	✓	✓	✓	✓	✓	✓	✓	✓	✓	✓	✓	✓	✓	✓	✓	✓	✓	✓	✓	✓	✓	✓	✓	✓	✓
1	✓	✓	✓	✓	✓	✓	✓	✓	✓	✓	✓	✓	✓	✓	✓	✓	✓	✓	✓	✓	✓	✓	✓	✓	✓
1.1.2	✓	✓	✓	✓	✓	✓	✓	✓	✓	✓	✓	✓	✓	✓	✓	✓	✓	✓	✓	✓	✓	✓	✓	✓	✓
2	✓	✓	✓	✓	✓	✓	✓	✓	✓	✓	✓	✓	✓	✓	✓	✓	✓	✓	✓	✓	✓	✓	✓	✓	✓
3				✓	✓	✓	✓	✓	✓	✓	✓	✓	✓	✓	✓	✓	✓	✓	✓	✓	✓	✓	✓	✓	✓
4				✓	✓	✓	✓	✓	✓	✓	✓	✓	✓	✓	✓	✓	✓	✓	✓	✓	✓	✓	✓	✓	✓
6				✓	✓	✓	✓	✓	✓	✓	✓	✓	✓	✓	✓	✓	✓	✓	✓	✓	✓	✓	✓	✓	✓
8				✓	✓	✓	✓	✓	✓	✓	✓	✓	✓	✓	✓	✓	✓	✓	✓	✓	✓	✓	✓	✓	✓
10				✓	✓	✓	✓	✓	✓	✓	✓	✓	✓	✓	✓	✓	✓	✓	✓	✓	✓	✓	✓	✓	✓
12									✓	✓	✓	✓	✓	✓	✓	✓	✓	✓	✓	✓	✓	✓	✓	✓	✓
14									✓	✓	✓	✓	✓	✓	✓	✓	✓	✓	✓	✓	✓	✓	✓	✓	✓
16									✓	✓	✓	✓	✓	✓	✓	✓	✓	✓	✓	✓	✓	✓	✓	✓	✓
18									✓	✓	✓	✓	✓	✓	✓	✓	✓	✓	✓	✓	✓	✓	✓	✓	✓
20									✓	✓	✓	✓	✓	✓	✓	✓	✓	✓	✓	✓	✓	✓	✓	✓	✓
24									✓	✓	✓	✓	✓	✓	✓	✓	✓	✓	✓	✓	✓	✓	✓	✓	✓
28 to 48									On request					On request						On request					

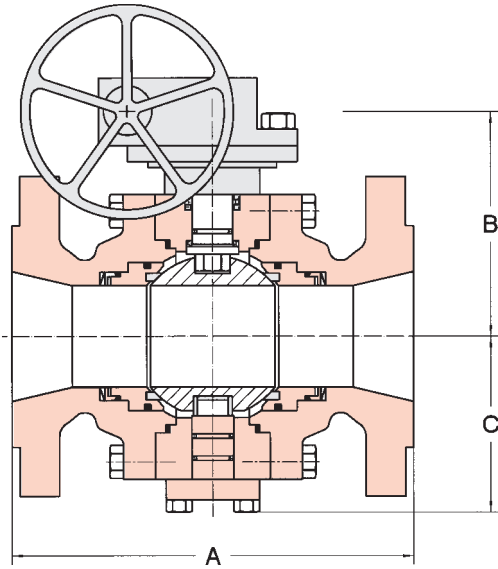

RATINGS: Carbon Steel  
 Class 150-275 p.s.i. @ 100°F-Seat PTFE + Graphite  
 Class 300-720 p.s.i. @ 100°F-Seat PTFE + Graphite  
 Class 600-1440 p.s.i. @ 100°F-Seat PTFE + Graphite  
 Class 900-2160 p.s.i. @ 100°F-Seat Nylon

## CLASS 150-300-600-900 REDUCED BORE-TRUNNION MOUNTED SIDE ENTRY BALL VALVES

Integral flanges - End to End According to API 6D Flange Dimensions to ANSI B16.5

REDUCED BORE	DN	50x40		80x50		100x80		150x100		200x150		250x200		300x250		350x300		400x350		450x400		500x450		600x550		
		IN	2"x1 1/2"	3"x2"	4"x3"	6"x4"	8"x6"	10"x8"	12"x10"	14"x12"	16"x14"	18"x16"	20"x18"	24"x20"	mm	in.	mm	in.	mm	in.	mm	in.	mm	in.	mm	in.
BSE Class 150	A	-	-	203	7.99	229	9.01	394	15.51	457	17.99	533	20.98	610	24.01	686	27.00	762	30.00	864	34.01	914	35.98	1067	42.00	
BSE Class 300	A	216	8.50	283	11.14	305	12.00	403	15.86	502	19.76	568	22.36	648	25.51	762	30.00	838	32.99	914	35.98	991	39.01	1143	45.00	
BSE Class 600	A	292	11.49	356	14.01	432	17.00	559	22.00	660	25.98	787	30.98	838	32.99	889	35.00	991	39.01	1092	42.99	1194	47.00	1397	55.00	
BSE Class 900	A	369	14.52	381	15.00	458	18.03	610	24.01	737	29.01	839	33.03	966	38.03	1029	40.51	1131	44.52	1220	48.03	1321	52.00	1549	60.98	
Center to Top	Class 150	B	-	-	140	5.51	190	7.48	280	11.02	295	11.61	330	12.99	400	15.74	460	18.11	480	18.89	540	21.25	580	22.83	715	28.14
	Class 300	B	175	6.88	200	7.87	240	9.44	280	11.02	295	11.61	330	12.99	420	16.53	465	18.30	545	21.45	600	23.62	620	24.40	734	28.89
	Class 600	B	190	7.48	356	14.01	240	9.44	280	11.02	305	12.00	400	15.74	435	17.12	440	17.32	505	19.88	590	23.22	700	27.55	775	30.51
	Class 900	B	155	6.10	200	7.87	240	9.44	280	11.02	350	13.77	390	15.35	480	18.89	438	17.24	545	21.45	650	25.59	675	26.57	790	31.10
Center to Bottom	Class 150	C	-	-	90	3.54	105	4.13	166	6.53	175	6.88	210	8.26	250	9.84	310	12.20	340	13.38	385	15.15	428	16.85	545	21.45
	Class 300	C	80	3.14	120	4.72	130	5.11	150	5.90	175	6.88	210	8.26	270	10.62	325	12.79	430	16.92	470	18.50	510	20.07	500	19.68
	Class 600	C	90	3.54	110	4.33	110	4.33	175	6.88	195	7.67	280	11.02	285	11.22	320	12.59	340	13.38	410	16.10	445	17.51	510	20.07
	Class 900	C	108	4.25	120	4.72	130	5.11	175	6.88	220	8.66	260	10.23	310	12.20	410	16.14	370	14.56	420	16.53	617	24.29	725	28.54

WITH LEVER | WITH GEAR

RATINGS: Carbon Steel  
 Class 1500-3600 p.s.i. @ 100°F-Seat Nylon  
 Class 2500-6000 p.s.i. @ 100°F-Seat Nylon

## CLASS 1500-2500 REDUCED BORE - TRUNNION MOUNTED SIDE ENTRY BALL VALVES

Integral Flanges - End to End According to API 6D Flange dimensions to ANSI B16.5

REDUCED BORE	DN	40X25		50X40		80X50		100X80		150X100		200X150		250X200		300X250		350x300		400x350		
		IN	1 1/2"x1	2"x1.1/2"	3"x2"	4"x3"	6"x4"	8"x6"	10"x8"	12"x10"	14"x12"	16"x14"	mm	in.	mm	in.	mm	in.	mm	in.	mm	in.
BSE Class 1500	A	-	-	368	14.48	470	18.50	546	21.49	705	27.75	832	32.75	991	39.01	1130	44.48	1257	49.5	1384	54.5	
BSE Class 2500	A	384	15.11	451	17.75	578	22.75	673	26.49	914	35.98	-	-	-	-	-	-	-	-	-		
Center to Top	Class 1500	B	-	-	190	7.48	205	8.07	210	8.26	245	9.64	335	13.18	410	16.14	465	18.30	553	21.77	626	24.64
	Class 2500	B	185	7.28	200	7.87	215	8.46	220	8.66	255	10.03	-	-	-	-	-	-	-	-		
Center to Bottom	Class 1500	C	-	-	110	4.33	120	4.72	125	4.92	160	6.29	255	10.03	290	11.41	335	13.18	438	17.24	498	19.6
	Class 2500	C	105	4.13	120	4.72	130	5.11	135	5.31	170	6.69	-	-	-	-	-	-	-			

WITH LEVER | WITH GEAR

# TRUNNION FULL BORE

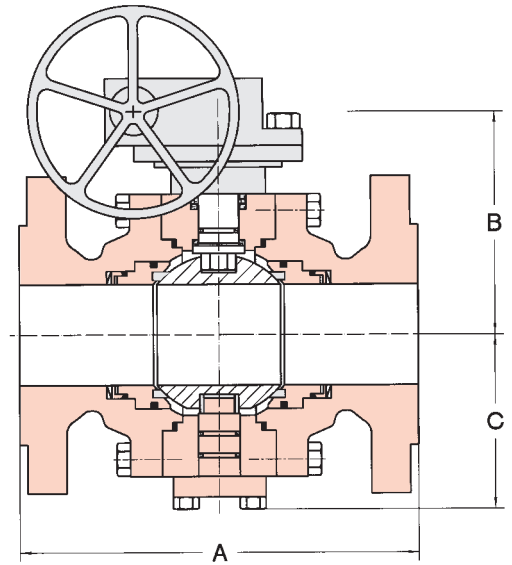
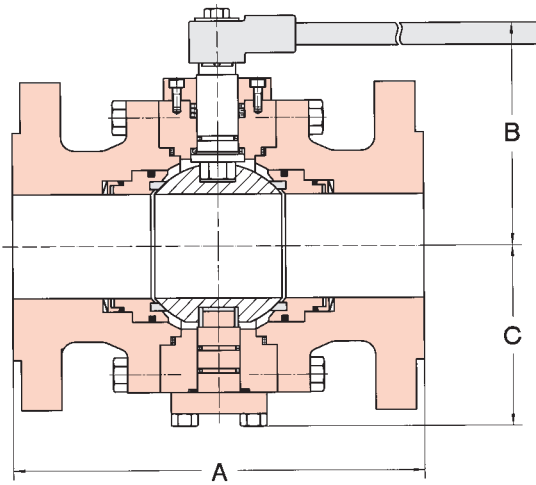

RATINGS: Carbon Steel  
 Class 150-275 p.s.i. @ 100°F-Seat PTFE + Graphite  
 Class 300-720 p.s.i. @ 100°F-Seat PTFE + Graphite  
 Class 600-1440 p.s.i. @ 100°F-Seat PTFE + Graphite  
 Class 900-2160 p.s.i. @ 100°F-Seat Nylon

## CLASS 150-300-600-900

**FULL BORE - TRUNNION MOUNTED SIDE ENTRY BALL VALVES**  
 Integral flanges - End to End According to API 6D Flange Dimensions to ANSI B16.5

FULL BORE	DN	50		80		100		150		200		250		300		350		400		450		500		600		
		IN	2"	3"	4"	6"	8"	10"	12"	14"	16"	18"	20"	24"	mm	in.	mm	in.	mm	in.	mm	in.	mm	in.	mm	in.
BSE Class 150	<b>A</b>	178	7.00	203	7.99	229	9.01	394	15.51	457	17.99	533	20.98	610	24.0	686	27.00	762	30.00	864	34.01	914	36.56	1067	42.00	
BSE Class 300	<b>A</b>	216	8.50	283	11.14	305	12.00	403	15.86	502	19.76	568	22.36	648	25.51	762	30.00	838	32.99	914	35.98	991	39.01	1143	45.00	
BSE Class 600	<b>A</b>	292	11.49	356	14.01	432	17.00	559	22.00	660	25.98	787	30.98	838	32.99	889	35.00	991	39.01	1092	42.99	1194	47.00	1397	55.00	
BSE Class 900	<b>A</b>	369	14.52	381	15.00	458	18.03	610	24.01	737	29.01	839	33.03	966	38.03	1029	40.51	1131	44.52	1220	48.03	1321	52.00	1549	61.96	
Center to Top	Class 150	<b>B</b>	140	5.51	190	7.48	247	9.72	295	11.61	330	12.99	400	15.74	460	18.11	480	18.89	540	21.25	580	22.83	715	28.14	780	30.70
	Class 300	<b>B</b>	200	7.87	240	9.44	247	9.72	295	11.61	330	12.99	420	16.53	465	18.30	545	21.45	600	23.62	620	24.40	734	28.89	780	30.70
	Class 600	<b>B</b>	195	7.67	240	9.44	280	11.02	305	12.00	400	15.74	435	17.12	440	17.32	505	19.88	590	23.22	700	27.55	775	30.51	840	33.07
	Class 900	<b>B</b>	200	7.87	240	9.44	280	11.02	350	13.77	390	15.35	480	18.89	438	17.24	545	21.45	650	25.59	675	26.57	790	31.10	915	36.02
Center to Bottom	Class 150	<b>C</b>	90	3.54	105	4.13	141	5.55	175	6.88	210	8.26	250	9.84	310	12.20	340	13.38	385	15.15	428	16.85	545	21.45	655	25.78
	Class 300	<b>C</b>	120	4.72	130	5.11	141	5.55	175	6.88	210	8.26	270	10.62	325	12.79	430	16.92	470	18.50	510	20.07	500	19.68	600	23.62
	Class 600	<b>C</b>	110	4.33	110	4.33	175	6.88	195	7.67	280	11.02	285	11.22	320	12.59	340	13.38	410	16.14	445	17.51	510	20.07	640	25.19
	Class 900	<b>C</b>	120	4.72	130	5.11	175	6.88	220	8.66	260	10.23	310	14.20	410	16.14	370	14.56	420	16.53	617	24.29	725	28.54	831	32.71

WITH LEVER | WITH GEAR

RATINGS: Carbon Steel  
 Class 1500-3600 p.s.i. @ 100°F-Seat Nylon  
 Class 2500-6000 p.s.i. @ 100°F-Seat Nylon

## CLASS 1500-2500

**FULL BORE-TRUNNION MOUNTED SIDE ENTRY BALL VALVES**  
 Integral Flanges - End to End According to API 6D Flange dimensions to ANSI B16.5

FULL BORE	DN	25		40		50		80		100		150		200		250		300		350		400	
		IN	1"	1 1/2"	2"	3"	4"	6"	8"	10"	12"	14"	16"	mm	in.	mm	in.	mm	in.	mm	in.	mm	in.
BSE Class 1500	<b>A</b>	-	-	305	12.00	368	14.48	470	18.50	546	21.49	705	27.75	832	32.75	991	39	1131	44.5	1257	49.48	1384	54.5
BSE Class 2500	<b>A</b>	308	12.12	384	15.11	451	17.75	578	22.75	673	26.49	914	36	-	-	-	-	-	-	-	-	-	
Center to Top	Class 1500	<b>B</b>	-	190	7.48	205	8.07	210	8.26	245	9.64	335	13.18	437	17.2	502	19.76	533	20.98	626	24.64	725	28.54
	Class 2500	<b>B</b>	185	7.28	200	7.87	215	8.46	220	8.66	255	10.03	430	16.92	-	-	-	-	-	-	-	-	
Center to Bottom	Class 1500	<b>C</b>	-	110	4.33	120	4.72	125	4.92	160	6.29	255	10.03	340	13.38	381	15	438	17.24	498	19.6	460	18.11
	Class 2500	<b>C</b>	105	4.13	120	4.72	130	5.11	135	5.31	170	6.69	265	10.43	-	-	-	-	-	-	-	-	

WITH LEVER | WITH GEAR

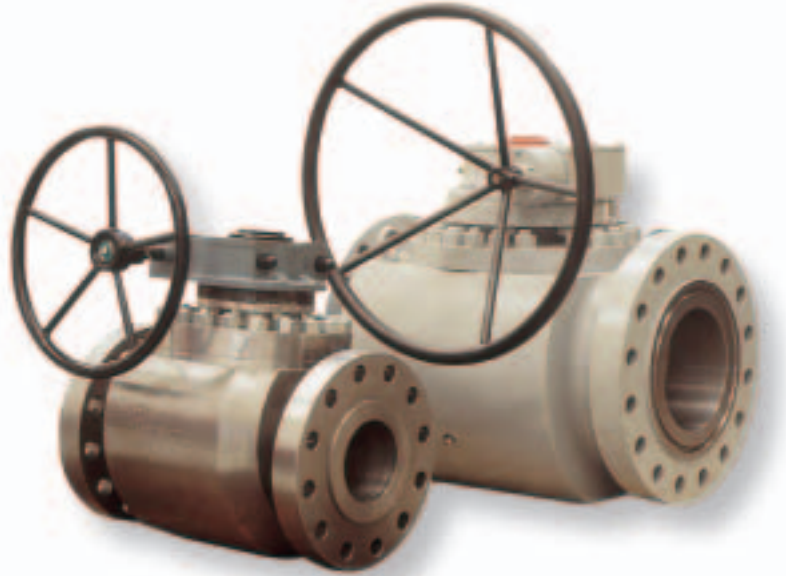
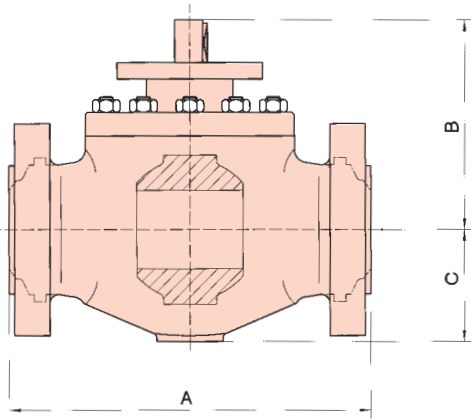

RATINGS: Carbon Steel  
 Class 150-275 p.s.i. @ 100°F-Seat PTFE + Graphite  
 Class 300-720 p.s.i. @ 100°F-Seat PTFE + Graphite  
 Class 600-1440 p.s.i. @ 100°F-Seat PTFE + Graphite  
 Class 900-2160 p.s.i. @ 100°F-Seat Nylon  
 Class 1500-3600 p.s.i. @ 100°F-Seat Nylon

## CLASS 150-300-600-900-1500

### FULL BORE - TRUNNION MOUNTED - TOP ENTRY BALL VALVES

Integral flanges - End to End According to API 6D Flange Dimensions to ANSI B16.5

FULL BORE	DN	50		80		100		150		200		250		300		350		400		450		500		600		
	IN	2"	3"	4"	6"	8"	10"	12"	14"	16"	18"	20"	24"	mm	in.	mm	in.	mm	in.	mm	in.	mm	in.	mm	in.	
BTE Class 150	<b>A</b>	178	7.00	203	7.99	229	9.01	394	15.51	457	17.99	533	20.98	610	24.0	686	27.00	762	30.00	864	34.01	914	36.56	1067	42.00	
BTE Class 300	<b>A</b>	216	8.50	283	11.14	305	12.00	403	15.86	502	19.76	568	22.36	648	25.51	762	30.00	838	32.99	914	35.98	991	39.01	1143	45.00	
BTE Class 600	<b>A</b>	292	11.49	356	14.01	432	17.00	559	22.00	660	25.98	787	30.98	838	32.99	889	35.00	991	39.01	1092	42.99	1194	47.00	1397	55.00	
BTE Class 900	<b>A</b>	369	14.52	381	15.00	458	18.03	610	24.01	737	29.01	839	33.03	966	38.03	1029	40.51	1131	44.52	1220	48.03	13.21	52.00	1549	61.96	
BTE Class 1500	<b>A</b>	368	14.48	470	18.50	546	21.49	705	27.75	832	32.75	991	39	1131	44.5	1257	49.48	1384	54.5	-	-	-	-	-	-	
Center to Top	Class 150	<b>B</b>	140	5.51	190	7.48	280	11.02	295	11.61	330	12.99	400	15.74	460	18.11	480	18.89	540	21.25	580	22.83	715	28.14	780	30.70
	Class 300	<b>B</b>	200	7.87	240	9.44	280	11.02	295	11.61	330	12.99	420	16.53	465	18.30	545	21.45	600	23.62	620	24.40	734	28.89	780	30.70
	Class 600	<b>B</b>	195	7.67	240	9.44	280	11.02	305	12.00	400	15.74	435	17.12	440	17.32	505	19.88	590	23.22	700	27.55	775	30.51	840	33.07
	Class 900	<b>B</b>	200	7.87	240	9.44	280	11.02	350	13.77	390	15.35	480	18.89	438	17.24	545	21.45	650	25.59	675	26.57	790	31.10	915	36.02
	Class 1500	<b>B</b>	205	8.07	210	8.26	245	9.64	335	13.18	437	17.2	502	19.76	533	20.98	626	24.64	725	28.54	-	-	-	-	-	-
Center to Bottom	Class 150	<b>C</b>	90	3.54	105	4.13	166	6.53	175	6.88	210	8.26	250	9.84	310	12.20	340	13.38	385	15.15	428	16.85	545	21.45	655	25.78
	Class 300	<b>C</b>	120	4.72	130	5.11	150	5.90	175	6.88	210	8.26	270	10.62	325	12.79	430	16.92	470	18.50	510	20.07	500	19.68	600	23.62
	Class 600	<b>C</b>	110	4.33	110	4.33	175	6.88	195	7.67	280	11.02	285	11.22	320	12.59	340	13.38	410	16.14	445	17.51	510	20.07	640	25.19
	Class 900	<b>C</b>	120	4.72	130	5.11	175	6.88	220	8.66	260	10.23	310	14.20	410	16.14	370	14.56	420	16.53	617	24.29	725	28.54	831	32.71
	Class 1500	<b>C</b>	120	4.72	125	4.92	160	6.29	255	10.03	340	13.38	381	15	438	17.24	498	19.6	460	18.11	-	-	-	-	-	-

## CLASS 150-300-600-900-1500

### REDUCED BORE - TRUNNION MOUNTED - TOP ENTRY BALL VALVES

Integral flanges - End to End According to API 6D Flange Dimensions to ANSI B16.5

FULL BORE	DN	50x40		80x50		100x80		150x100		200x150		250x200		300x250		350x300		400x350		450x400		500x450		600x550		
	IN	2"x11/2"	3"x2"	4"x3"	6"x4"	8"x6"	10"x8"	12"x10"	14"x12"	16"x14"	18"x16"	20"x18"	24"x20"	mm	in.	mm	in.	mm	in.	mm	in.	mm	in.	mm	in.	
BTE Class 150	<b>A</b>	178	7.00	203	7.99	229	9.01	394	15.51	457	17.99	533	20.98	610	24.0	686	27.00	762	30.00	864	34.01	914	36.56	1067	42.00	
BTE Class 300	<b>A</b>	216	8.50	283	11.14	305	12.00	403	15.86	502	19.76	568	22.36	648	25.51	762	30.00	838	32.99	914	35.98	991	39.01	1143	45.00	
BTE Class 600	<b>A</b>	292	11.49	356	14.01	432	17.00	559	22.00	660	25.98	787	30.98	838	32.99	889	35.00	991	39.01	1092	42.99	1194	47.00	1397	55.00	
BTE Class 900	<b>A</b>	369	14.52	381	15.00	458	18.03	610	24.01	737	29.01	839	33.03	966	38.03	1029	40.51	1131	44.52	1220	48.03	13.21	52.00	1549	61.96	
BTE Class 1500	<b>A</b>	368	14.48	470	18.50	546	21.49	705	27.75	832	32.75	991	39.01	1131	44.5	1257	49.48	1384	54.5	-	-	-	-	-	-	
Center to Top	Class 150	<b>B</b>	209	8.22	140	5.51	190	7.48	280	11.02	295	11.61	330	12.99	400	15.74	460	18.11	480	18.89	540	21.25	580	22.84	715	28.14
	Class 300	<b>B</b>	209	8.22	200	7.87	240	9.44	280	11.02	295	11.61	330	12.99	420	16.53	465	18.30	545	21.45	600	23.62	620	24.40	734	28.89
	Class 600	<b>B</b>	209	8.22	195	7.67	240	9.44	280	11.02	305	12.00	400	15.74	435	17.12	440	17.32	505	19.88	590	23.22	700	27.55	775	30.51
	Class 900	<b>B</b>	215	8.46	200	7.87	240	9.44	280	11.02	350	13.77	390	15.35	480	18.89	438	17.24	545	21.45	650	25.59	675	26.57	790	31.10
	Class 1500	<b>B</b>	220	8.66	205	8.07	210	8.26	245	9.64	335	13.18	437	17.2	502	19.76	533	20.98	626	24.64	-	-	-	-	-	-
Center to Bottom	Class 150	<b>C</b>	70	2.75	90	3.54	105	4.13	166	6.53	175	6.88	210	8.26	250	9.84	310	12.20	340	13.38	385	15.15	428	16.85	545	21.45
	Class 300	<b>C</b>	70	2.75	120	4.72	130	5.11	150	5.90	175	6.88	210	8.26	270	10.62	325	12.79	430	16.92	470	18.50	510	20.07	500	19.68
	Class 600	<b>C</b>	70	2.75	110	4.33	110	4.33	175	6.88	195	7.67	280	11.02	285	11.22	320	12.59	340	13.38	410	16.14	445	17.51	510	20.07
	Class 900	<b>C</b>	80	3.14	120	4.72	130	5.11	175	6.88	220	8.66	260	10.23	310	14.20	410	16.14	370	14.56	420	16.53	617	24.29	725	28.54
	Class 1500	<b>C</b>	90	3.54	120	4.72	125	4.92	160	6.29	255	10.03	340	13.38	381	15.01	438	17.24	498	19.6	-	-	-	-	-	-

# FULL WELDED BALL VALVES

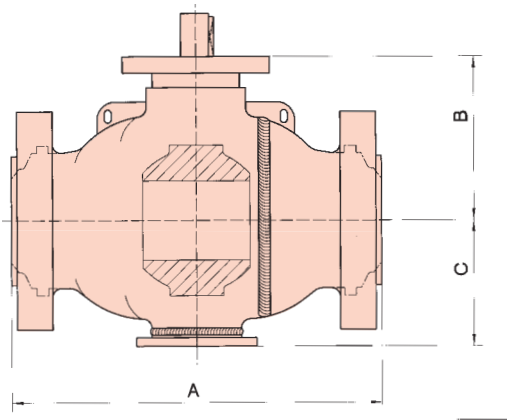

RATINGS: Carbon Steel  
 Class 150-275 p.s.i. @ 100°F-Seat PTFE + Graphite  
 Class 300-720 p.s.i. @ 100°F-Seat PTFE + Graphite  
 Class 600-1440 p.s.i. @ 100°F-Seat PTFE + Graphite

## CLASS 150-300-600

### FULL BORE - TRUNNION MOUNTED - FULL WELDED BALL VALVES

Integral flanges - End to End According to API 6D Flange Dimensions to ANSI B16.5

FULL BORE	DN	50		80		100		150		200		250		300		350		400		450		500		600			
		IN		2"		3"		4"		6"		8"		10"		12"		14"		16"		18"		20"		24"	
		mm	in.	mm	in.	mm	in.	mm	in.	mm	in.	mm	in.	mm	in.	mm	in.	mm	in.	mm	in.	mm	in.	mm	in.	mm	in.
WSE Class 150	<b>A</b>	178	7.00	203	7.99	229	9.01	394	15.51	457	17.99	533	20.98	610	24.0	686	27.00	762	30.00	838	32.99	914	35.98	991	39.01	1143	45.00
WSE Class 300	<b>A</b>	216	8.50	283	11.14	305	12.00	403	15.86	502	19.76	568	22.36	648	25.51	762	30.00	838	32.99	914	35.98	991	39.01	1143	45.00		
WSE Class 600	<b>A</b>	292	11.49	356	14.01	432	17.00	559	22.00	660	25.98	787	30.98	838	32.99	889	35.00	991	39.01	1092	42.99	1194	47.00	1397	55.00		
Center to Top	Class 150	<b>B</b>	140	5.51	190	7.48	280	11.02	295	11.61	330	12.99	400	15.74	460	18.11	480	18.89	540	21.25	580	22.83	715	28.14	780	30.70	
	Class 300	<b>B</b>	200	7.87	240	9.44	280	11.02	295	11.61	330	12.99	420	16.53	465	18.30	545	21.45	600	23.62	620	24.40	734	28.89	780	30.70	
	Class 600	<b>B</b>	195	7.67	240	9.44	280	11.02	305	12.00	400	15.74	435	17.12	440	17.32	505	19.88	590	23.22	700	27.55	775	30.51	840	33.07	
Center to Bottom	Class 150	<b>C</b>	90	3.54	105	4.13	166	6.53	175	6.88	210	8.26	250	9.84	310	12.20	340	13.38	385	15.15	428	16.85	545	21.45	655	25.78	
	Class 300	<b>C</b>	120	4.72	130	5.11	150	5.90	175	6.88	210	8.26	270	10.62	325	12.79	430	16.92	470	18.50	510	20.07	500	19.68	600	23.62	
	Class 600	<b>C</b>	110	4.33	110	4.33	175	6.88	195	7.67	280	11.02	285	11.22	320	12.59	340	13.38	410	16.14	445	17.51	510	20.07	640	25.19	

## CLASS 150-300-600

### REDUCED BORE - TRUNNION MOUNTED - FULL WELDED BALL VALVES

Integral flanges - End to End According to API 6D Flange Dimensions to ANSI B16.5

FULL BORE	DN	50x40		80x50		100x80		150x100		200x150		250x200		300x250		350x300		400x350		450x400		500x450		600x550			
		IN		2"x11/2"		3"x2"		4"x3"		6"x4"		8"x6"		10"x8"		12"x10"		14"x12"		16"x14"		18"x16"		20"x18"		24"x20"	
		mm	in.	mm	in.	mm	in.	mm	in.	mm	in.	mm	in.	mm	in.	mm	in.	mm	in.	mm	in.	mm	in.	mm	in.	mm	in.
WSE Class 150	<b>A</b>	178	7.00	203	7.99	229	9.01	394	15.51	457	17.99	533	20.98	610	24.0	686	27.00	762	30.00	838	32.99	914	35.98	991	39.01	1143	45.00
WSE Class 300	<b>A</b>	216	8.50	283	11.14	305	12.00	403	15.86	502	19.76	568	22.36	648	25.51	762	30.00	838	32.99	914	35.98	991	39.01	1143	45.00		
WSE Class 600	<b>A</b>	292	11.49	356	14.01	432	17.00	559	22.00	660	25.98	787	30.98	838	32.99	889	35.00	991	39.01	1092	42.99	1194	47.00	1397	55.00		
Center to Top	Class 150	<b>B</b>	160	6.29	140	5.51	190	7.48	280	11.02	295	11.61	330	12.99	400	15.74	460	18.11	480	18.89	540	21.25	580	22.83	715	28.14	
	Class 300	<b>B</b>	175	6.88	200	7.87	240	9.44	280	11.02	295	11.61	330	12.99	420	16.53	465	18.30	545	21.45	600	23.62	620	24.40	734	28.89	
	Class 600	<b>B</b>	190	7.48	195	7.67	240	9.44	280	11.02	305	12.00	400	15.74	435	17.12	440	17.32	505	19.88	590	23.22	700	27.55	775	30.51	
Center to Bottom	Class 150	<b>C</b>	70	2.75	90	3.54	105	4.13	166	6.53	175	6.88	210	8.26	250	9.84	310	12.20	340	13.38	385	15.15	428	16.85	545	21.45	
	Class 300	<b>C</b>	80	3.14	120	4.72	130	5.11	150	5.90	175	6.88	210	8.26	270	10.62	325	12.79	430	16.92	470	18.50	510	20.07	500	19.68	
	Class 600	<b>C</b>	90	3.54	110	4.33	110	4.33	175	6.88	195	7.67	280	11.02	285	11.22	320	12.59	340	13.38	410	16.14	445	17.51	510	20.07	

CALOBRI valves are manufactured in a wide range of materials, supplied by the best available steel mills, forged by well experienced forgeries with the most up to date equipment. All the materials can be certified in the chemical composition and the mechanical characteristic.

MATERIAL SPECIFICATIONS FOR TRUNNION MOUNTED VALVES				
Service	Non sour		Sour	
Part Name	minus 45°C up to plus 180°C	minus 29°C up to plus 180°C	minus 45°C up to plus 180°C	minus 29°C up to plus 180°C
Body/Cover	LF2	A105 (N)	LF2	A105 (N)
Ball	LF2	A105 (N)	LF2 enp 0.075	A105 (N) enp 0.075
Seat	LF2	A105 (N)	LF2 enp 0.075	A105 (N) enp 0.075
Stem	LF2	A105 (N)	LF2 enp 0.075	A105 (N) enp 0.075
Trunnion	LF2	A105 (N)	LF2 enp 0.075	A105 (N) enp 0.075
Seat Insert*	Rife or nylon or devlon	Rife or nylon or devlon	Rife or nylon or devlon	Rife or nylon or devlon
Seal	Viton	Viton	Viton	Viton
Springs	Inconel X750	Inconel X750	Inconel X750	Inconel X750
Bolting	L7/4	B7/2H	L7M/4M	B7M/2M
Adaptor Plate	A105	A105	A105	A105
Screws	Gr 8.8 Zinc plated	Gr 8.8 Zinc plated	Gr 8.8 Zinc plated	Gr 8.8 Zinc plated
<b>Bill of Materials</b>	<b>BM1</b>	<b>BM2</b>	<b>BM3</b>	<b>BM4</b>
	(LF2/LF2)	(A105N/A105N)	(LF2/LF2 enp 0.075)	(A105N/A105N enp 0.075)

\* Selection of seat insert is limited by the actual service temperature  
metal to metal seatings are also available

MATERIAL SPECIFICATIONS FOR TRUNNION MOUNTED VALVES			
SERVICE	High Temperature	Marine Offshore	Corrosive
Part Name	minus 29°C up to plus 260°C	minus 29°C up to plus 180°C	minus 180°C up to plus 210°C
Body/Cover	A105 (N)	Duplex F51	F316
Ball	A105 enp 0.075	Duplex F51	F316 (or Tungsten)
Seat	A105 enp 0.075	Duplex F51	F316 (or Tungsten)
Stem	17-4PH	Duplex F51	17-4PH
Trunnion	A105 enp. 0.075	Duplex F51	F316
Seat Insert*	Peek	Rife or nylon or devlon or peek	Rife or nylon or Kel-F
Seal	Viton or pife + inconel	Viton	Viton
Springs	Inconel X750	Inconel X750	Inconel X750
Bolting	B7/2H	B8M/8M	B8/8
Adaptor Plate	A105	316	st/st 316
Screws	Gr 8.8 zinc plated	A4-70	A4-70
<b>Bill of Materials</b>	<b>BM5</b>	<b>BM6</b>	<b>BM7</b>
	(A105/A105 enp 0.075 - 17-4PH)	(F51/F51)	(F316/316 enp 0.025 - 17-4PH)

\* Selection of seat insert is limited by the actual service temperature  
metal to metal seatings are also available



# TRANSITION PIECES



The ball Valves can be furnished with transition pieces of different length to facilitate the installation of valve and piping on site. Always do specify the length of transition pieces.

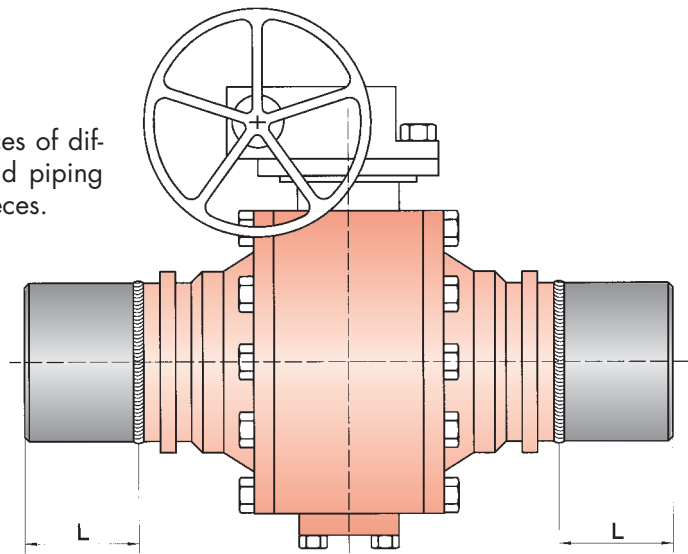

# EXTENTION DETAIL FOR AUXILIARY PIPES

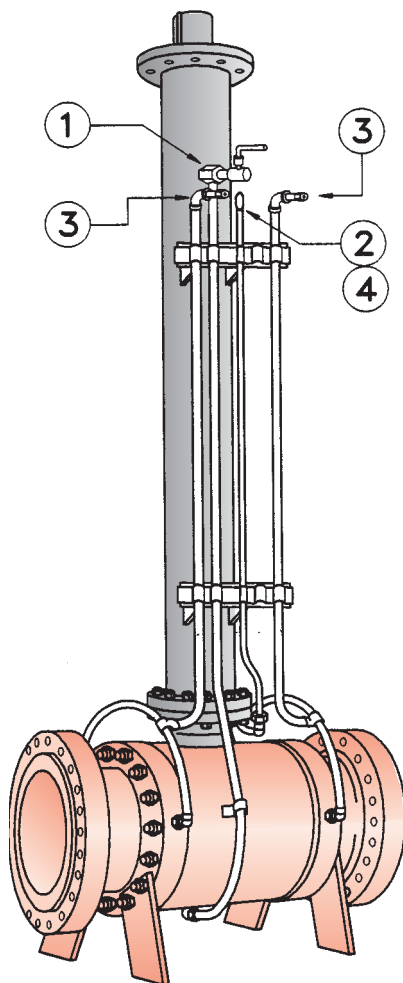

Often for valves buried or installed underground their operation and the accessibility to their auxiliary connections, need to be brought at ground level.

This requires an extension of the stem and all the piping connections. The extension always needs to be specified.

- 1- Drain extension
- 4-2 Grease stem seal extension or stem seal control extension
- 3- Grease seat seal

#### NOTE

- 1) Grease seat seal only on request
- 2) Relief valve only on request or if there is a liquid medium



**Warranty Policy:** CALOBRI products are warranted against defects in design, materials or workmanship. This warranty is limited to the use of our products as recommended and intended. This warranty applies for one year from start-up, but not exceeding eighteen months after shipment, provided that the valves are stored in a protected environment, and it is limited to the replacement of defective parts only. Any modification performed on CALOBRI products by any firm other than those authorized by CALOBRI in writing, negates the warranty.

CALOBRI valves are manufactured in a wide range of materials, supplied by the best available steel mills, forged by well experienced forgeries with the most up to date equipment. All the materials can be certified in the chemical composition and the mechanical characteristic.

MATERIAL SPECIFICATIONS FOR TRUNNION MOUNTED VALVES				
Service	Non sour		Sour	
Part Name	<i>minus 45°C up to plus 180°C</i>	<i>minus 29°C up to plus 180°C</i>	<i>minus 45°C up to plus 180°C</i>	<i>minus 29°C up to plus 180°C</i>
Body/Cover	LF2	A105 (N)	LF2	A105 (N)
Ball	LF2	A105 (N)	LF2 enp 0.075	A105 (N) enp 0.075
Seat	LF2	A105 (N)	LF2 enp 0.075	A105 (N) enp 0.075
Stem	LF2	A105 (N)	LF2 enp 0.075	A105 (N) enp 0.075
Trunnion	LF2	A105 (N)	LF2 enp 0.075	A105 (N) enp 0.075
Seat Insert*	Rffe or nylon or devlon	Rffe or nylon or devlon	Rffe or nylon or devlon	Rffe or nylon or devlon
Seal	Viton	Viton	Viton	Viton
Springs	Inconel X750	Inconel X750	Inconel X750	Inconel X750
Bolting	L7/4	B7/2H	L7M/4M	B7M/2M
Adaptor Plate	A105	A105	A105	A105
Screws	Gr 8.8 Zinc plated	Gr 8.8 Zinc plated	Gr 8.8 Zinc plated	Gr 8.8 Zinc plated
<b>Bill of Materials</b>	<b>BM1</b>	<b>BM2</b>	<b>BM3</b>	<b>BM4</b>
	(LF2/LF2)	(A105N/A105N)	(LF2/LF2 enp 0.075)	(A105N/A105N enp 0.075)

\* Selection of seat insert is limited by the actual service temperature  
metal to metal seatings are also available

MATERIAL SPECIFICATIONS FOR TRUNNION MOUNTED VALVES			
SERVICE	High Temperature	Marine Offshore	Corrosive
Part Name	<i>minus 29°C up to plus 260°C</i>	<i>minus 29°C up to plus 180°C</i>	<i>minus 180°C up to plus 210°C</i>
Body/Cover	A105 (N)	Duplex F51	F316
Ball	A105 enp 0.075	Duplex F51	F316 (or Tungsten)
Seat	A105 enp 0.075	Duplex F51	F316 (or Tungsten)
Stem	17-4PH	Duplex F51	17-4PH
Trunnion	A105 enp. 0.075	Duplex F51	F316
Seat Insert*	Peek	Rffe or nylon or devlon or peek	Rffe or nylon or Kel-F
Seal	Viton or pife + inconel	Viton	Viton
Springs	Inconel X750	Inconel X750	Inconel X750
Bolting	B7/2H	B8M/8M	B8/8
Adaptor Plate	A105	316	st/st 316
Screws	Gr 8.8 zinc plated	A4-70	A4-70
<b>Bill of Materials</b>	<b>BM5</b>	<b>BM6</b>	<b>BM7</b>
	(A105/A105 enp 0.075 - 17-4PH)	(F51/F51)	(F316/316 enp 0.025 - 17-4PH)

\* Selection of seat insert is limited by the actual service temperature  
metal to metal seatings are also available

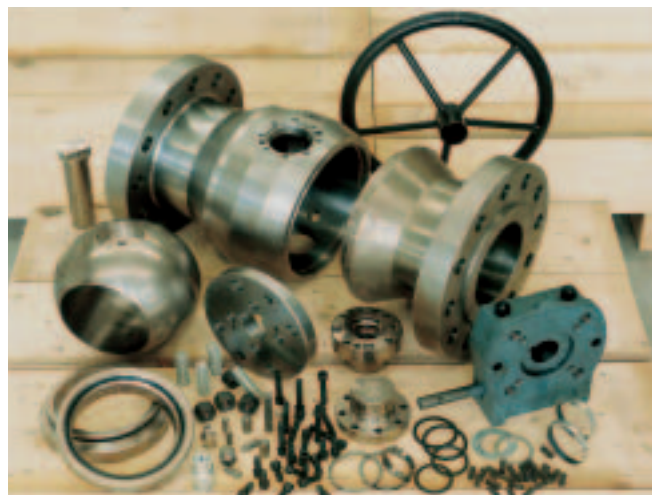
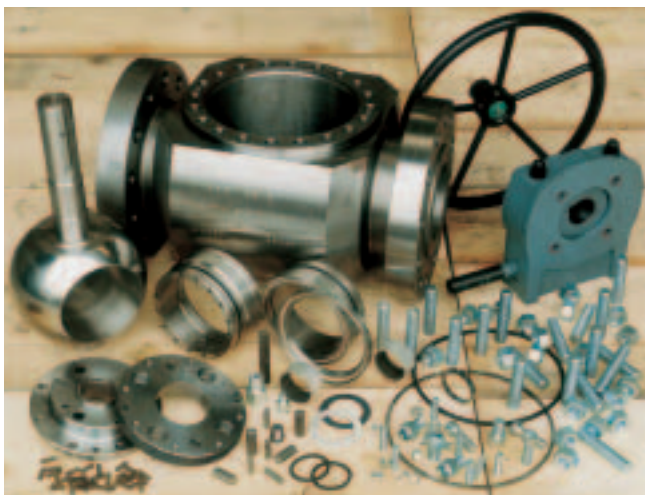



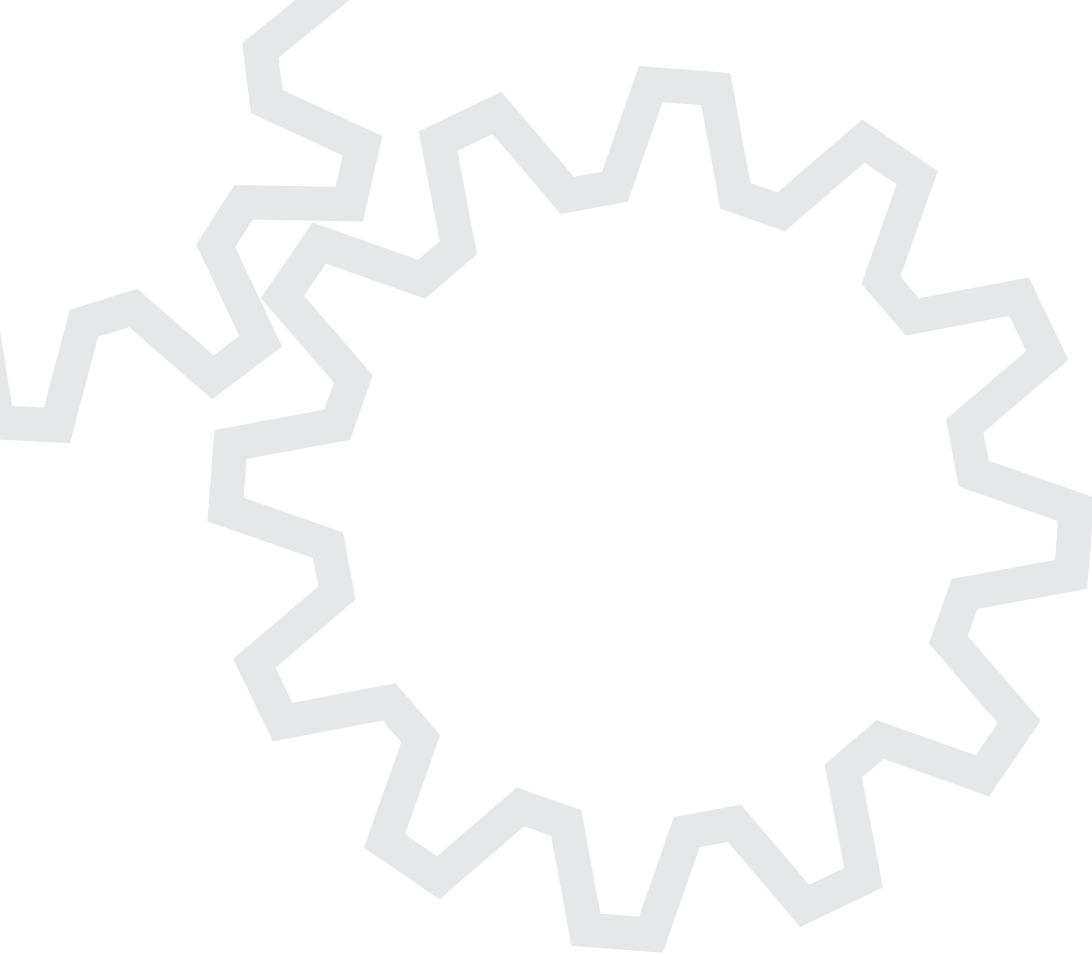

Via Giacomo Leopardi, 10  
20019 Settimo Milanese - Milan, ITALY  
tel. +39 02.3282951  
fax +39 02.3281558

[www.calobri.com](http://www.calobri.com)  
[www.calobriusa.com](http://www.calobriusa.com)

**LOCAL DISTRIBUTOR:**